

REDUCING
GEAR
WHINE IN
PLANETARY
GEAR
TRANS-
MISSIONS

By Shounak M. Athavale, Ph.D.

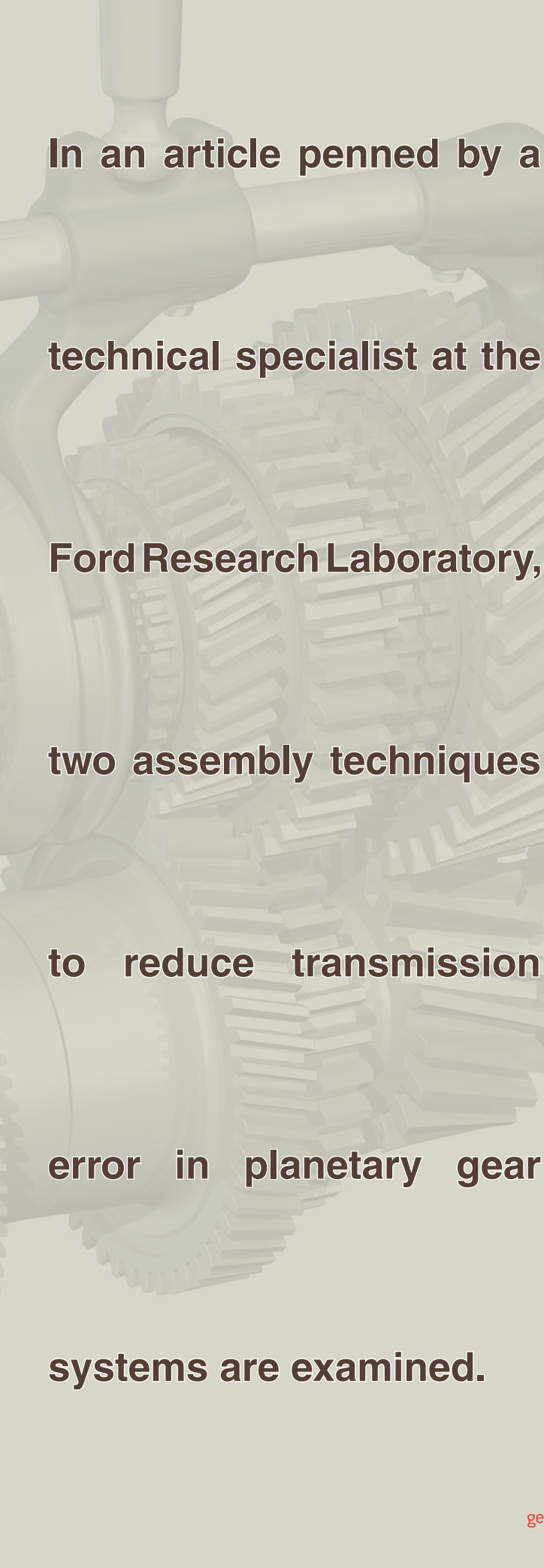

In an article penned by a technical specialist at the Ford Research Laboratory, two assembly techniques to reduce transmission error in planetary gear systems are examined.

Gear whine is an annoyance for automotive consumers. For all practical purposes it cannot be eliminated, but only minimized. Gear whine stems from transmission error that is a result of manufacturing variation, among other things. Random assembly used in current mass production can be a hindrance to reducing transmission error and, therefore, the gear whine. Two alternate selective assembly techniques to reduce transmission error of planetary gear systems are examined in this paper. The selective assembly strategies are based on statistical characterization of gear profiles from in-plant inspection data. The effectiveness of these strategies against the random assembly is discussed. Also, the selection criterion for each strategy is developed and, a brief discussion about the pros and cons of switching to selective assembly is also included.

Introduction

Gear whine is a high frequency pure tone, which is noticeable in lower gears and goes away with gearshift. Although gear whine is undesirable from the consumer point of view, it cannot be eliminated completely. The root causes of gear whine are dimensional variability and dynamic deflections of the gear teeth and carrier, as well as misalignment errors during assembly.

Typically, a planetary gear system (Figure 1) is not necessarily designed with the primary intent to reduce gear whine. The primary design considerations are the ability to transmit torque, mechanical efficiency, and durability. Nominal dimensions of planetary gear system are determined to satisfy these primary constraints along with any packaging requirements. Manufacturing process capability and design robustness dictate the tolerances allocated to these nominal dimensions. Thus, even properly controlled manufacturing process can prove to be detrimental, from a gear whine perspective. The dynamic stack-up of small manufacturing variations sway driven gears away from their respective ideal conjugate angular position. This error in the angular position of the driven gear is referred to as transmission error [Dunn et al. 1999]. For simple gear systems,

transmission error correlates very well with the gear whine [Lorea et al., 1986, Chung et al. 1999].

Measurement of transmission error is quite challenging, and researchers have succeeded in measuring transmission error for single mesh two-gear systems [Dunn et al., 1999]. There are several prediction models for the transmission error of single mesh systems [Livtin, 1994, Smith, 1999, Beacham et al. 1999, Dunn et al. 1999, Donley, et al. 1992]. Predicting a single value of transmission error for most practical cases is not advisable, because even for a single mesh system (only two mating gears) multiple teeth with unique dimensions provide ample statistical variability. Thus both a mechanics/kinematics and statistics-based model for predicting transmission errors is required. There is a clear lack of validated predictive models for planetary gear systems. Also, the measurement techniques for planetary transmission error are non-existent. However, the effect of tooth profile/assembly variation on gear whine can be measured experimentally [Athavale et al. 2002]. This paper utilizes a transmission error estimate (cMTE) for a Simpson-type planetary system [Athavale et al. 2001].

The gear whine is typically evaluated using subjective ratings or objective measures like sound pressure or accelerometer signature [Becker and Yu, 1999]. There are two prevalent approaches to dealing with the gear whine issue, namely: 1) strive for perfection (minimum deviation) during manufacturing and assembly [Remmers, 1972, Sundaresan et al., 1990, Ariga et al., 1992, Su and Houser 1998] or; 2) isolation and absorption of the whine and vibration [Dunn et al., 1999]. Minimizing of errors or perfect manufacturing/assembly process advocated by the first approach has diminishing returns if pushed beyond conventional mass production capability. Also, such perfection is difficult to maintain over time. Further random assembly of gears with typical dimensional variation results in a large spread in gear whine (Figure 2). This wide spread makes the isolation/absorption of gear whine expensive and, in extreme cases, ineffective. An alternative is to utilize selective assembly strategies

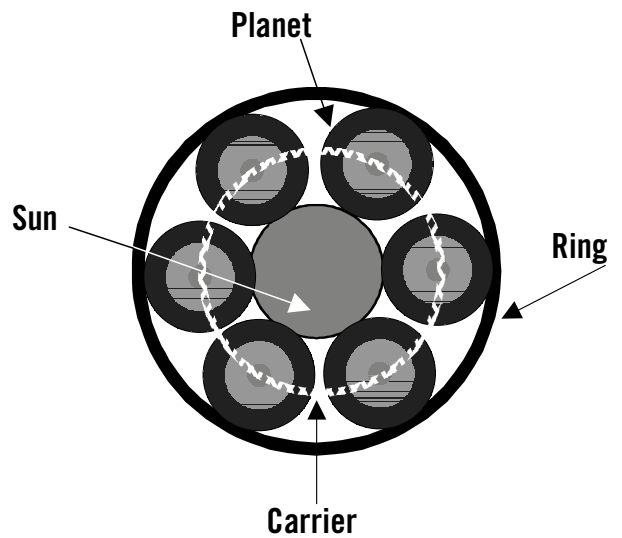

FIG 1: SIMPSON-TYPE PLANETARY GEAR SYSTEM

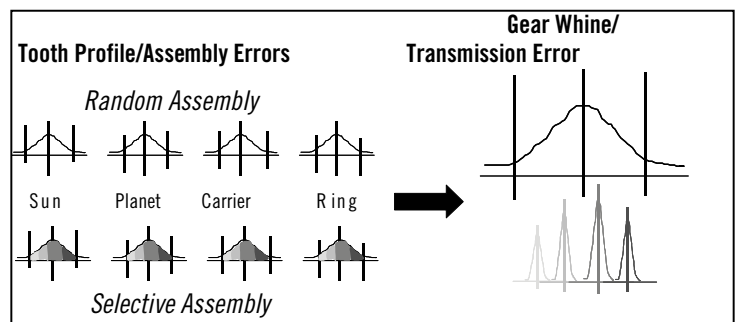

FIG 2: RANDOM VS. SELECTIVE ASSEMBLY

that result in multiple distributions with mean shifts, but less scatter (Figure 2). Bearing, mount, and case designs may be able to compensate for the mean shifts. Also, isolation/absorption may be effective because of narrow distributions.

This paper examines two strategies for selective planetary gear assembly as an alternative to current random assembly technique. The effectiveness of these strategies will depend on the criterion used for selection of the components and the ease of in-plant implementation. In this work the selection of components is limited to sun and planet populations. The ring gear, as well as the carrier, are assumed to be ideal. Assembly is assumed to be void of any errors. The planetary system will have six planets, as shown in Figure 1. No load transmission error [Athavale et. al., 2001] is used as an indicator of gear whine. Measured variation of the sun and planet gear tooth profile will be used in computation of the transmission error (MTE or cMTE) for each strategy. Detailed description of gear manufacture and inspection, as well as the measured data, is included in the experimental work section. Note that the gear manufacturing processes were under control during whole experiment. Hence, the dimensional variation observed in the data is due to machine-to-machine or shift-to-shift variation and any manufacturing process drift. The measurements are subject to gage reliability and repeatability (R&R). The gage R&R was conducted to ensure that it has minimum effect on the measurements.

Experimental Work

The goal of the experimental work is to determine statistical data for gear tooth profile variation before assembly. Recall that the ring gear and the carrier are assumed to be ideal and no assembly errors are considered. The design data for all gears is listed in Table 1.

The gears used in the experimental work were manufactured by hobbing a rough tooth profile in a cylindrical gear blank. The rough tooth profile is

Tooth Profile Errors

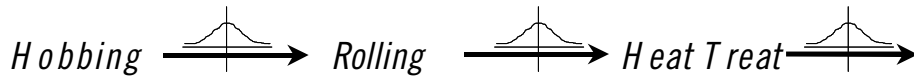

FIG3: GEAR MANUFACTURING PROCESS

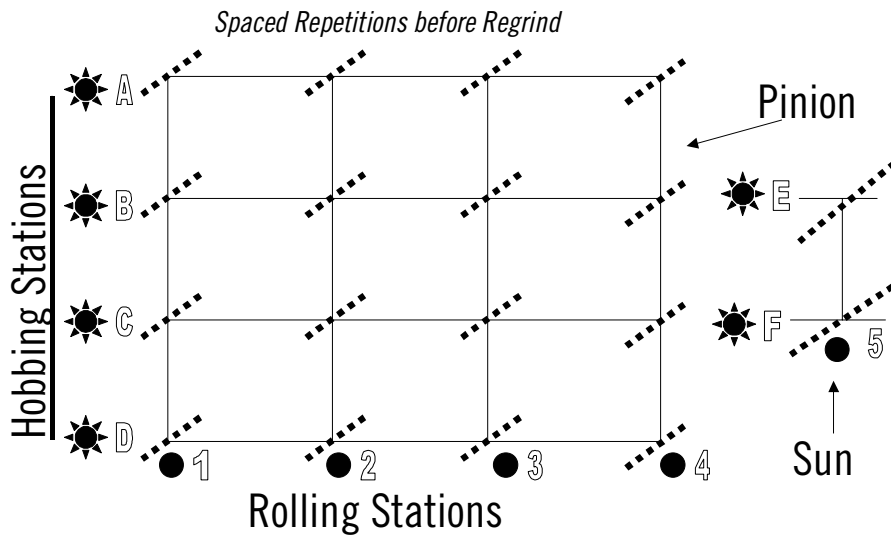

FIG 4: DESIGN OF EXPERIMENT

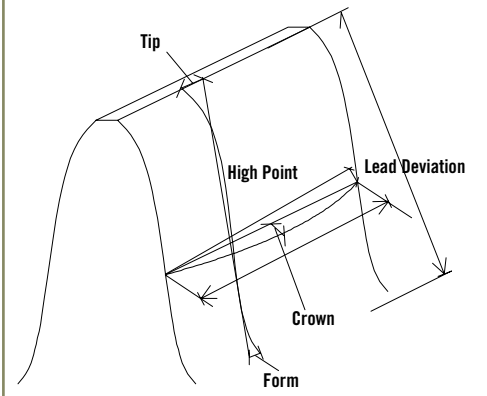

FIG 5: GEAR PROFILE MEASUREMENT

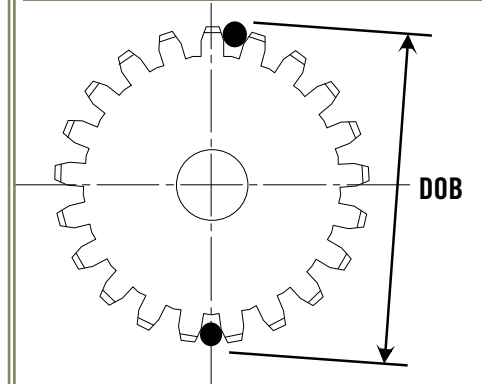

FIG 6: DOB MEASUREMENT

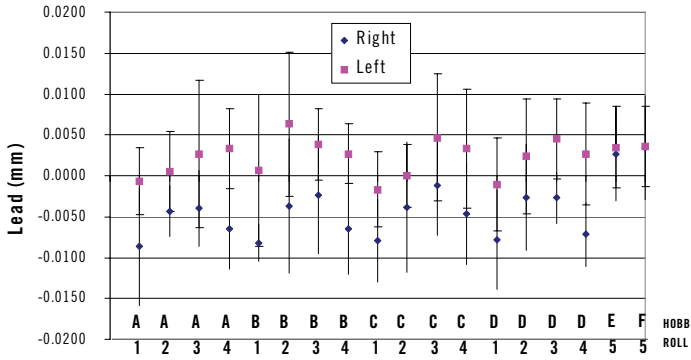

FIG 7: LEAD MEASUREMENT

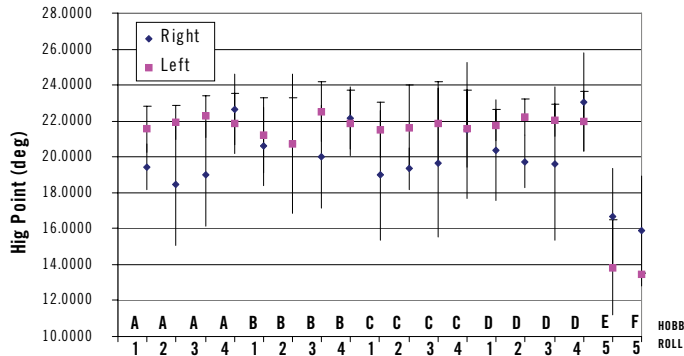

FIG 8: HIGH POINT MEASUREMENT

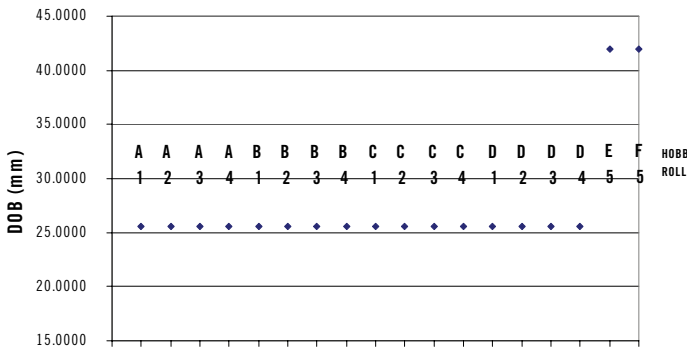

FIG 9: DOB MEASUREMENT

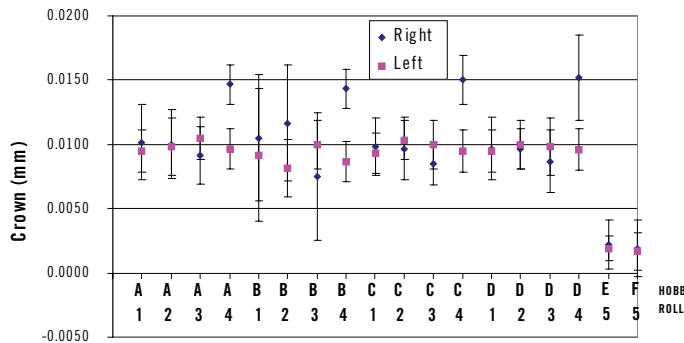

FIG 10: CROWN MEASUREMENT

finished with a rolling operation, followed by batch heat treatment. The final gear profile variation after the heat treatment contributes to gear transmission. Nevertheless the combination of hobbing and rolling stations indirectly contribute to the transmission error (Figure 3). The design of experiment (Figure 4) accommodates multiple stations for hobbing and rolling processes. Also, these combinations provide a basis for implementing selective assembly as opposed to end of line sorting. As more pinions are needed than suns, there are four hobbing stations (A-D) along with four rolling stations (1-4) used to process pinions. In the case of suns, only two hobbing stations (E-F) and one rolling station (5) are sufficient. Note that six and 10 samples for each pinion and sun combination, respectively, are measured. These samples are selected at predetermined intervals, beginning soon after the hobbing cutter installation and ending just before the cutter needs regrinding. Thus the measurements include the effect of hobbing cutter wear, and disregard any regrind effects. Further, these samples span all three shifts and several days. Since the rolling dies are wear resistant, the effect of the die wear is neglected.

The gear profile of both right and left flank is measured along two orthogonal curves in the lead and involute direction (Figure 5) [Moderow, 1990]. Five parameters, the tip and root (form) fall offs, location of high point in terms of roll angle of the involute, crown, and lead were measured, along with the diameter over balls (DOB) (Figure 9). Four equally spaced teeth for each gear were measured. Figures 7-12 show the mean and spread of these measurements for all hob-roll station combinations (Figure 4).

Assembly Strategies

Gear whine is an unavoidable side effect of manufacturing variability and design. Random assembly can lead to error stack-ups that are dynamic in nature and result in wide swings in transmission error, as depicted in

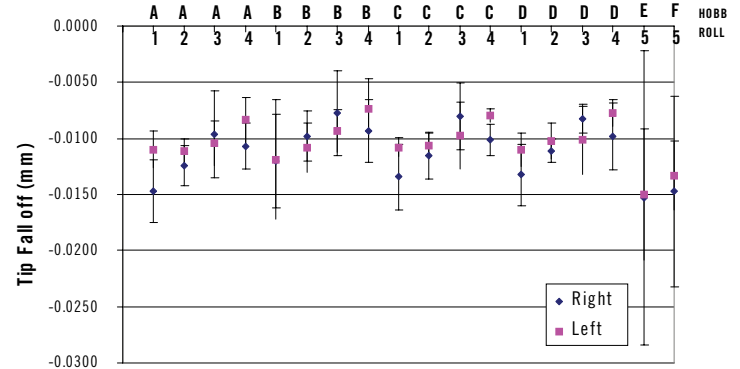

FIG 11: TIP FALL-OFF MEASUREMENT

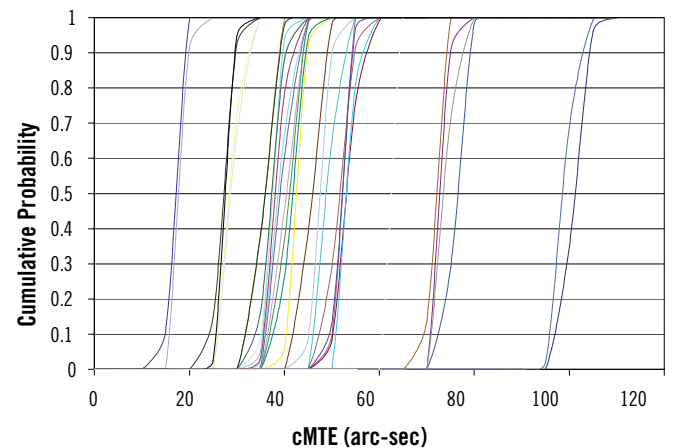

FIG 12: FORM FALL-OFF MEASUREMENT

Figure 2. Two selective assembly strategies are proposed to offset gear whine variability exhibited by random assembly. Both strategies categorize the gears in several groups and then select the groups of the gears to be assembled. The first strategy exploits natural groupings of hobbing and rolling stations. The gears produced by a particular combination of hobbing and rolling station are grouped together instead of sorting. On the other hand, the second strategy is based on measuring each gear and sorting them in different groups. Transmission error estimates (cMTE or MTE) are used to determine the effectiveness of each strategy.

The first strategy adds complexity because the gears must be carefully tracked from one station to the next. On the other hand, the second strategy adds an extra step of measuring each and every gear. Note that the first strategy also includes measurement of a statistical sample, but not

all gears. Hence, it is efficient. An alternative to this approach is to have much tighter tolerances for gears and carriers, which translates to additional investment (like for gear grinding, precision hole making for carrier) and increased variable maintenance. If the complexity can be managed, then selective assembly is preferred.

Random Assembly

In case of random assembly, the gears from any of the 32 combinations (16:pinion, 2:sun) can be used to assemble a planetary gear system. There are 8,008 ways to pick six planets from 16 station combinations. Also, there are two sun populations to choose from. Thus, there will be as many as 16,016 combinations. For this discussion it is assumed that all six planets in a planetary must belong to a single group. In other words,

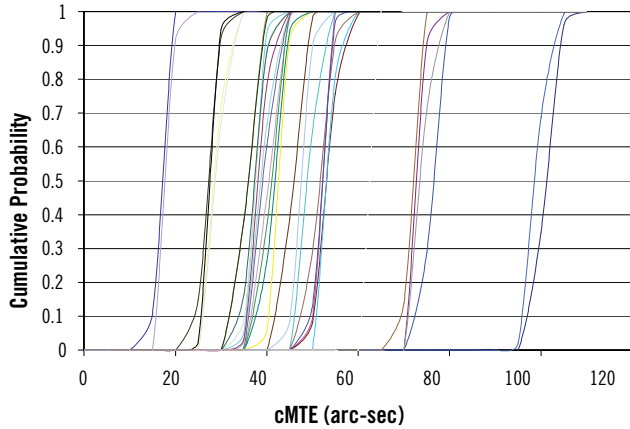

FIG 13: CMTE PREDICTIONS

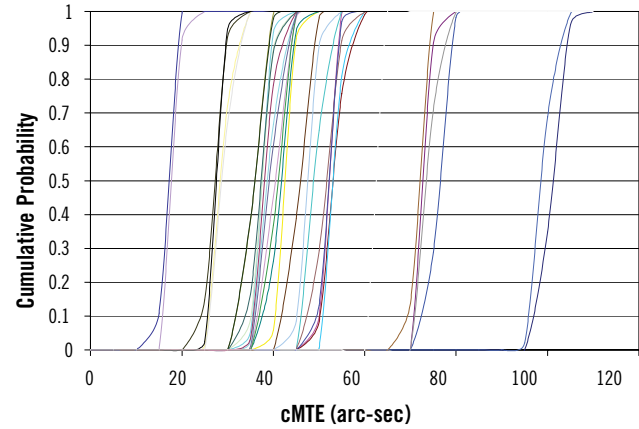

FIG 14: CROSS-POPULATION CMTE SENSITIVITY

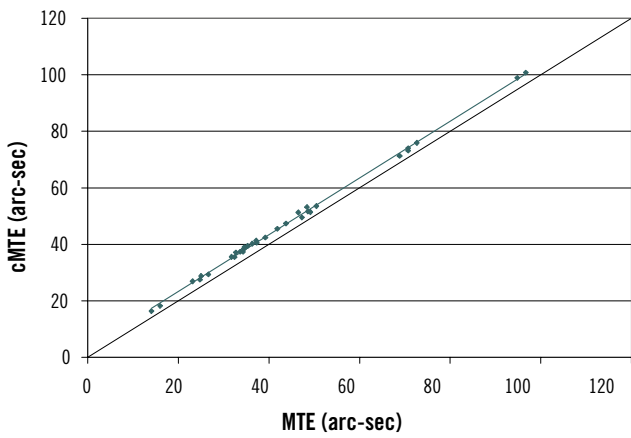

FIG 15: CMTE-MTE RELATIONSHIP

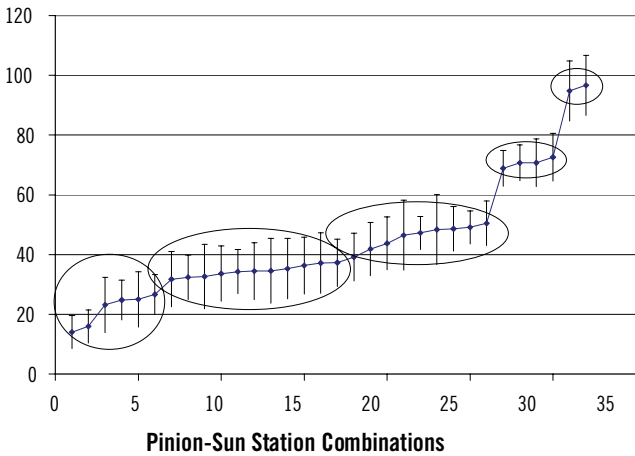
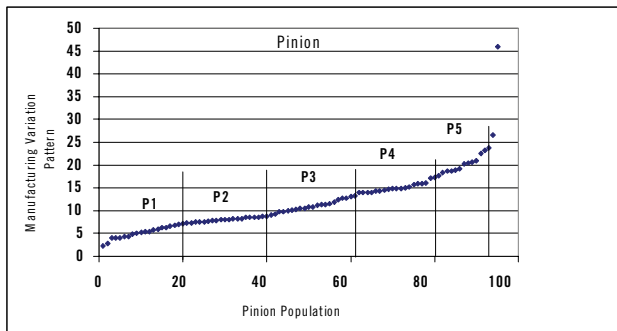
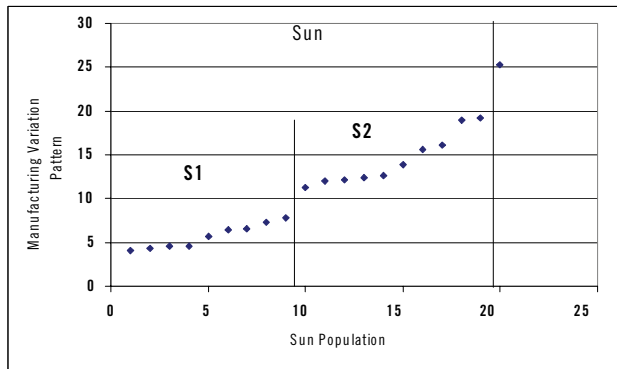

FIG 16: CROSS-POPULATION CMTE SENSITIVITY



(a)



(b)

FIG 17: MANUFACTURING VARIATION PATTERN

the effect of cross-group combination of planets is ignored. The cMTE predictions for these 32 (16x2) combinations are shown in Figure 13. Note that the transmission error (cMTE) varies from 15 to 115 arc-seconds. As a rule of thumb, doubling the transmission error will increase the gear whine by 6 dB [Houser, 1991]. Note that not all of the whine generated at the source will resonate through the passenger compartment. The gear whine inside the passenger compartment depends on the transmission path and the design of the passenger compartment itself.

Recall that the cMTE is an upper bound estimate of planetary transmission error. It is highly influenced by the worst-case scenario. Figure 14 shows the effect of including one planet from the worst combination (extreme right) along with five planets from the best combination (extreme left). The curve in the middle (Figure 14) displays cMTE for the combination. Thus, if the gears were truly selected in random, the net effect will be to push the gear whine distribution to the right hand side. On the other hand, better combinations (toward the left) in Figure 13 will have distinctly lower gear whine. Thus, to exploit this variation the gears must be grouped selectively. The first strategy is to selectively group these 32 combinations into manageable natural groups. The second strategy is to measure and sort the complete population.

Selective Assembly I

As described previously, this strategy includes groupings of selected combinations. However, MTE (transmission error with one planet) is used to match the groups during assembly rather than cMTE (transmission error with six planets). Adding additional planets shifts the mean transmission error, provided that all the planets are from the same population. Figure 15 illustrates this for the 32 combinations in Figure 13. Hence, only MTE will be used to select the group combinations. Further, as shown in Figure 14, the worst-case combination controls the cMTE estimate. Hence, the highest MTE in the group combinations will be used as a representative upper bound for cMTE for that group. Figure 16 shows the MTEs for the 32 groups and their groupings. There are five groups with the upper bound MTEs of about 25, 38, 51, 73, and 97 as opposed to 100 for random assembly. However, the scatter due to some random combinations will still exist, which can be decreased by going to a 100 percent sort of the whole population. This is the second strategy that will be evaluated next.

Selective Assembly II

In this strategy a complete population of gears is sorted, grouped, and assembled appropriately. Note that the selection criterion for the previous assembly strategy was predetermined from the MTE predictions based on routine in-plant inspections of few samples. Once the combinations are determined, it is easy to keep track of gears as they pass through particular station combinations. However, for this strategy an explicit sorting criterion must be developed. It is assumed that the same inspection will be used for these gears as for the samples from the previous one. This should not affect any line rates, as this inspection will be done after

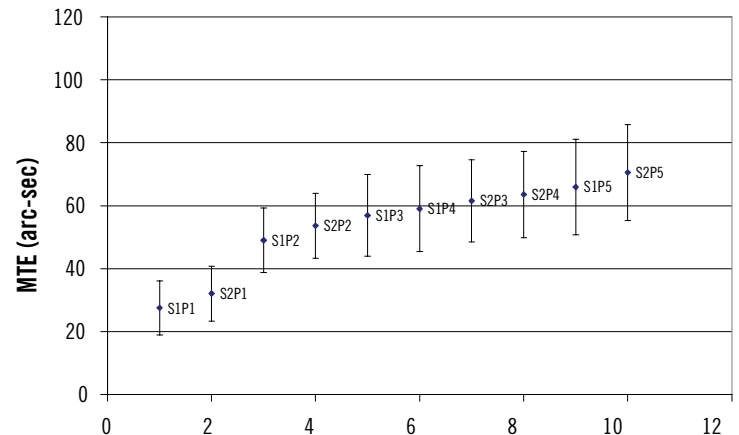

FIGURE 18. CROSS-POPULATION CMTE SENSITIVITY

	RING	PLANET	SUN
Base Diameter (mm)	75.7285	19.9285	35.8714
Pitch Diameter (mm)	82.1525	21.6191	38.9144
Tip Diameter (mm)	79.900	24.700	41.450
Number of Teeth (mm)	57	15	27
Normal Tooth Thickness (mm)	1.829	2.301	1.829

TABLE1: GEAR DESIGN PARAMETERS

the heat treatment, which is a batch process anyway. In other words, although the net time requirement goes up, the scheduling of hobbing and rolling stations does not change.

It is proposed to base the sorting of gears on the measured manufacturing variation. However, there are six measured parameters that constitute the deviation. To consolidate the effect of these parameters, a weighted least squares method is used. The multivariate statistical technique is also used for determining the impact of manufacturing variation on robustness of design [Yu and Ishii, 1998]. Basically, if the vec-

tor Y represents the measured parameters for a particular gear, and the vector M represents the mean of measured parameters for all gears, and Σ is the variance-covariance matrix for the whole population, then the manufacturing variation pattern is given by

$$(Y - M)^T \Sigma^{-1} (Y - M) \quad (1)$$

Figure 17 shows the manufacturing variation computed in this manner for both populations of pinions and suns. Note that the manufacturing variation pattern follows χ^2 distribution. Figure 17 also shows the groupings of pinions (five, P1-P5) and suns (two, S1-S2) with two pinions and one sun data discarded as outliers or unacceptable combined variations.

The MTE predictions for the 10 combinations (S1P1, S2P1, ..., S1P5, S2P5) are shown in Figure 18. Note that some of these groups can be combined, if necessary. However, the end result is similar to that of strategy I, except that the variation for this strategy is expected to be lower. For either strategy to succeed it is critical that gears are selected from the appropriate group. Further, it is imperative that the groups are isolated properly. In worst case, though, we are no worse than random assembly. Thus,

compared to random assembly there is no risk involved in implementing either of the selective strategies.

Summary

Two selective assembly strategies were presented as an alternative to conventional random assembly. The first assembly strategy was based on natural groupings of gears passing through a combination of hobbing and rolling stations, whereas the second strategy utilized a measure and sort technique. The selection criterion for the first strategy was the estimate of manufactured transmission error (MTE), while the selection criterion for the second strategy was manufacturing variation pattern (MVP). The first strategy requires complex implementation logistics, whereas the second strategy adds an additional step of measuring and sorting. Both strategies guarantee lower gear whine than random assembly. In the worst-case scenario, the two selective assembly strategies are no worse than the random assembly, thereby providing a no-loss solution. An alternative to the selective method is to achieve tighter tolerances using hard finishing methods. However, any process drift during hard finishing will not avoid the transmission error completely. 

REFERENCES:

- Ariga, K., T. Abe, Y. Yokoyama, and Y. Enomoto, (1992), "Reduction of Transaxle Gear Noise by Gear Train Modification," Proceedings of Worldwide Passenger Car Conference and Exposition, SAE Technical Paper 922108.
- Athavale, S. M., G. D. Gardner, and M. Trent, (2002), "Influence of Assembly Techniques, Misalignment Errors, and Manufacturing Variation on Noise and Vibration Characteristics of Automatic Transmission," Proceedings of Global Powertrain Engineering Conference, 2002.
- Athavale, S. M., R. Krishnaswami, and E. Y. Kuo, (2001), "Estimation of Statistical Distribution of Composite Manufactured Transmission Error, A Precursor to Gear Whine, for A Helical Planetary Gear System," Proceedings of 2001 SAE Noise & Vibration Conference & Exposition, SAE-2001-01-1507.
- Beacham, M. R., D. J. Bell, N. N. Powell, and M. T. Savage, (1999), "Development of Transmission Gear Whine Prediction Tools," Proceedings of the 1999 Noise and Vibration Conference, SAE Technical Paper 1999-01-1767.
- Becker, S., and S. Yu, (1999), "Objective Noise Rating of Gear Whine," Proceedings of the 1999 Noise and Vibration Conference, SAE Technical Paper 1999-01-1720.
- Dunn, A. L., D. R. Houser, and T. C. Lim, (1999), "Methods for Researching Gear Whine in Automotive Transaxles," Proceedings of the 1999 Noise and Vibration Conference, SAE Technical Paper 1999-01-1768.
- Chung, C-H., G. Steyer, T. Abe, M. Clapper, and C. Shah, (1999), "Gear Noise Reduction through Transmission Error Control and Gear Blank Dynamic Tuning," Proceedings of the 1999 Noise and Vibration Conference, SAE Technical Paper 1999-01-1766.
- Donley, M. G., T. C. Lim, and G. C. Steyer, (1992) "Dynamic Analysis of Automotive Gearing Subsystems," Proceedings of Transmission and Driveline Symposium: Components, Gears, and CAE, SAE Technical Paper 920762.
- Houser, D., (1991), "Gear Noise," Chapter 14, Dudley's Gear Handbook, 2nd Edition, McGraw Hill.
- Kin, V., (1994), "Computerized Analysis of Gear Meshing Based on Coordinate Measurement Data," Journal of Mechanical Design, ASME, vol. 116, pp. 738-744.
- Livtin, F. L., (1994), "Gear Geometry and Applied Theory," PTR Prentice Hall, ISBN 0-13-211095-4.
- Lorea, A., G. Morra, and G. Ruspa, (1986), "Advanced Statistical Methods for the Correlation Between Noise And Transmission Error in Gears," Proceedings of XXlth International Automobile Technical Congress, Yugoslav Society of Automotive Engineers, vol.2, pp. 2.285-2.290.
- Moderow, R. H., (1990), "Gear Inspection and Chart Interpretation," Gear Design, Manufacturing and Inspection Manual, SAE, pp. 527-548.
- Remmers, E. P., (1972), "Analytical Gear Tooth Profile Design," Proceedings of the ASME Mechanisms Conference and International Symposium on Gearing and Transmissions, ASME Paper 72-PTG47.
- Smith, J. D., (1999), "Gears and Their Vibration," Marcel Dekker, ISBN 0-8247-6005-0.
- Su, X., and D. R. Houser, (1998), "Programmable Separation of Runout From Profile and Lead Inspection Data for Gear Teeth with Arbitrary Modifications," Gear Technology, pp. 42-47.
- Sundaresan, S., K. Ishii, and D. R. Houser, (1990), "A Procedure That Accounts For Manufacturing Errors in The Design Minimization of Transmission Error in Helical Gears," AGMA, ISBN 1-55589-561-1.
- Yu, J.-c., and K. Ishii, (1998), "Design for Robustness Based on Manufacturing Patterns," Journal of Mechanical Design, vol. 120, pp. 196-202.

ABOUT THE AUTHOR:

Shounak M. Athavale, Ph.D., is a technical specialist at the Ford Research Laboratory of the Ford Motor Company. He can be reached at sathaval@ford.com. Go online to [\[www.ford.com\]](http://www.ford.com).

ACKNOWLEDGEMENT:

The author will like to acknowledge the assistance of R. Krishnaswami, M. DeFore, P. Faucon, L. DiRago, and Gear Inspection Team, Bourdeaux, for conducting the gear inspections. Copyright (©) 2002, Society of Manufacturing Engineers, SME Technical Paper TP02PUB93.