



THE RULES FOR **SUCCESSFUL ROTARY BROACHING**

When is rotary broaching applicable,
and how is the operation performed?
What materials can be used, and
which manufacturers benefit from this
process? You'll find the answers ahead!

By Scott Laprade

The process of rotary broaching has been around for a long time, but there are still many machinists in the field who have never heard of the process, or are skeptical to try it due to a lack of understanding of how the system works. As an example, many machining applications call for hexagonal shapes, Torx® / Hex lobular, square, or spline drives. Shops that have the ability to perform this operation may be missing an opportunity simply because they do not understand how rotary broaching can benefit them. Rotary broaching, also known as “wobble broaching,” has been one method used to obtain these various shapes.



FIG 1

Well known, and used for years on automatic lathes, rotary broaching has become the method of choice on Swiss-type machines, CNC lathes, and vertical machining centers because it eliminates a secondary operation and, in most cases, is more cost effective than shaping these profiles on a second machine to EDM or punching the form into part blanks (see fig. 1).

What Materials Can Be Broached?

According to PCM Willen SA of Switzerland,

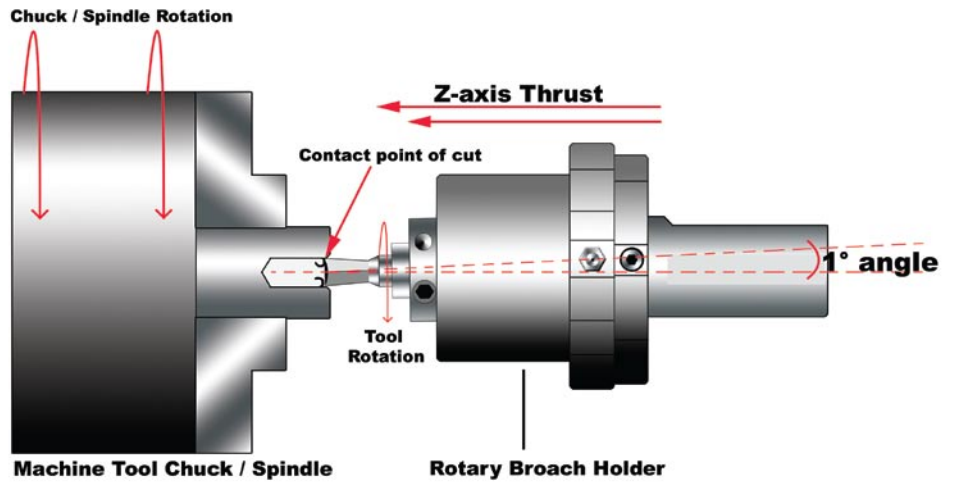

FIG 2

almost all free-cutting materials can be successfully broached up to 850N/mm² tensile strength without greatly reducing tool life. Materials such as heat treated steels and non-free cutting stainless will reduce tool life, depending on hardness.

How Rotary Broaching Works

The basic principle of rotary broaching is relatively simple. Internal and external polygonal profiles are single point shaped rather than form punched. The operation is performed

in only a few seconds while the spindle is rotating. PCM Willen reports that the cutting action requires 80 percent less force than form punching when the optimum feed rate is used. The reduced stress increases tool life and lowers machine maintenance cost over time.

On a machining center the broach holder revolves in the spindle, while the tool and part are stationary. It is the opposite on a lathe, where the part rotates synchronously with the tool while the holder is held in an ID position. The operation takes only seconds

.059 -.118 = .001 -.002

.118 -.236 = .0015 -.0035

.236 -.394 = .0025 -.005

.394 -.630 = .004 -.008

> .630 = .006 -.012

and can eliminate a secondary operation so the part can be produced complete in one setup.

The broaching holder serves two functions: it holds the broach tool in a free spinning bearing, and it places it at a 1° angle relative to the centerline of the work piece. The face of the broach tool is the apex of the 1° and is located on the same centerline as the work piece. Built into the tool is a 1-1/2° clearance angle. As the tool comes into contact with the spinning part, it begins to rotate synchronously like a gear due to friction. As the tool is thrust into the pre-drilled hole the wobble effect causes the leading edge to rotate in and out of the cut like a cam. As the tool advances forward in a wobbling motion, each tooth cuts the same groove with a chisel-like scalloping effect as it rotates in and out of the leading point. Similar to a wobbling coin, only one point is touching the work piece at any given time, greatly reducing the amount of force needed to form the shape (see fig. 2).

Drilling the Hole

The hole should first be prepared with a 60°-90° chamfer slightly bigger than the largest dimension of the broach tool. This ensures easy starting of the broach by guiding the tool in. For internal broaching, the hole should be drilled approximately 1 percent bigger than the diameter across the flats of a hex shape. This percentage can be reduced in free cutting material and increased as machinability decreases. In mild steel we recommend the following tolerances listed at top of page.

Drill the hole as deep as possible to leave room for chip accumulation. A depth of 1.3 to 1.5 times the length of the profile is recommended. If the chips need to be removed, re-drill the hole with a slightly smaller drill size after the broaching operation is completed.

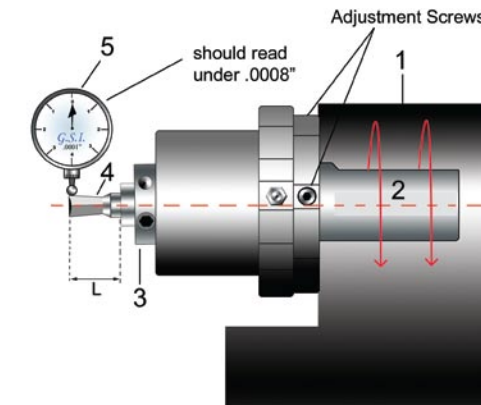

FIG 3

Drill Radius Not Allowed

Many tight tolerance applications such as aerospace parts do not allow for a drill radius along the broached walls of the part. When exact concentricity is required, counter-bore, drill, and pre-bore the hole, which will keep

the broach concentric when it enters the hole.

As the broach plunges into a tight fitting hole there is no room for air or coolant to escape. The hydraulic pressure being generated exerts enough force that something must give. Many times the part or tool will

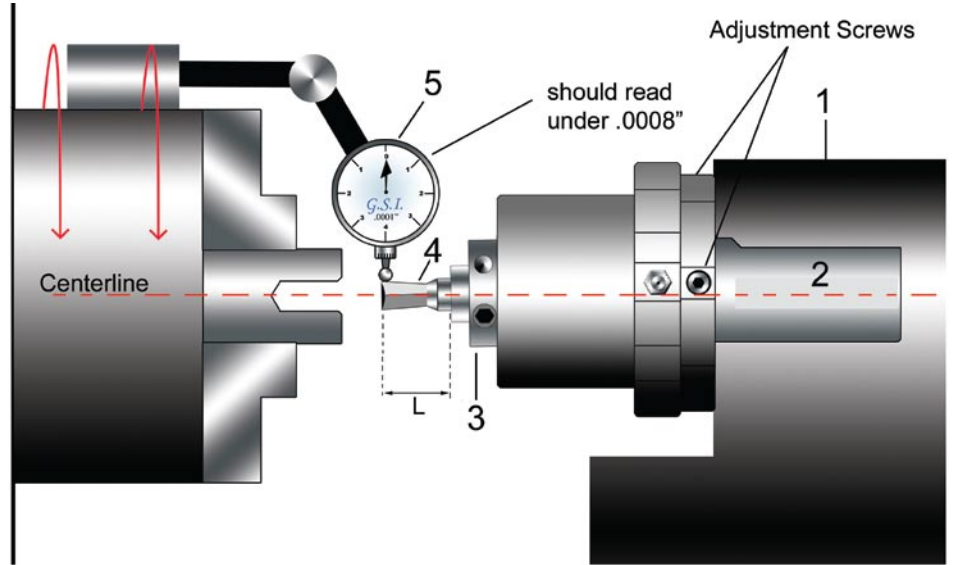

FIG 4

CANADA BROACH

TOOLS YOU CAN TRUST!

ROUND • FLAT • SPLINED
FORMS • PROFILES • DOVETAILES
DESIGN • MANUFACTURE • REGRIND
REPAIR • MODIFICATIONS

4478 Chesswood Drive • Unit #12
Downsview, Ontario M3J-2B9
Tel: (416) 398-9446
Fax: (416) 398-2348
E-mail: ninobroach@aol.com

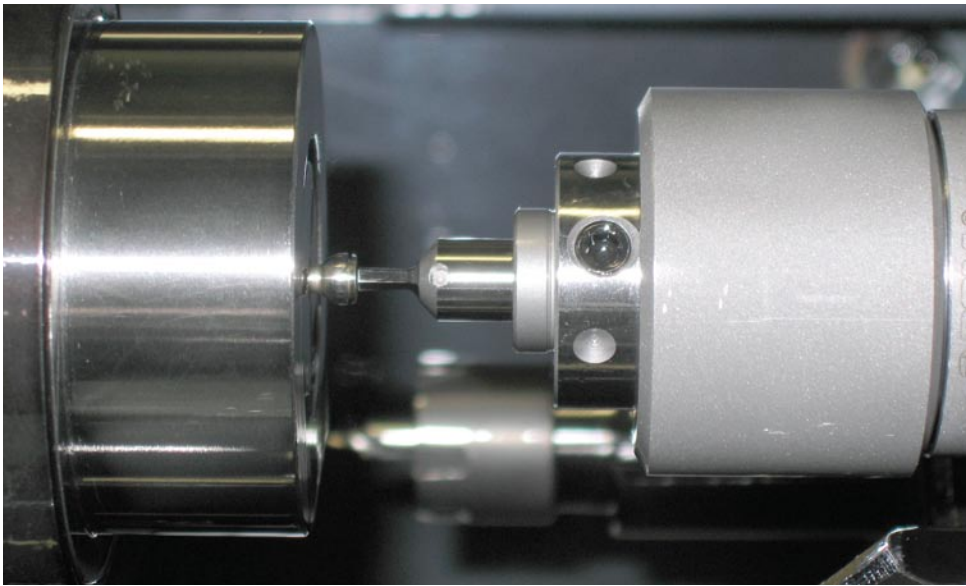

FIG 5

push back. However, the tool or machine can also be damaged. In this case a pressure relief vent in the broach is recommended, allowing oil and air to escape.

Recommended Speed

The basic principle of the 1° offset allows high-speed application from 1500 up to 3000 rpm. Surface footage has very little effect on cutting action or the tool life. The

cutting edges of the broach tend to dig in to the face of the part as the tool comes into contact with the rotating material. At higher speeds this “dig mark” will become more pronounced, and tool life will suffer. For best results start the broach operation at a slow rotation, and then increase the speed when it is in full contact. Reversing the spindle rotation halfway into the part can reduce spiraling.

Feed Rate

The feed choice mainly depends on the material characteristics. In a mild steel, we recommend .0012-.0024 per revolution. If the machine thrust force is sufficient, the feed can be doubled—and even tripled—as machinability increases. In most cases the maximum feed rate should not exceed .03 x the profile diameter. A slower feed rate will produce an improved finish, with finer lines along the side-walls of the broached hole. By increasing the feed rate the cutting cycle will be faster, but the broaching lines will be more pronounced, leaving a coarse finish.

Coolant

A water soluble coolant or cutting oil are both sufficient for rotary broaching. The increased size of the pre-drilled hole usually provides ample space for coolant to leak out as the broach tool plunges in. In a tight-fitting hole a pressure relief vent should be added to the broach tool.

Centering the Broach

To obtain a quality broached hole and optimize tool life, the tool should be on center with the work piece within .0008” or less. Poor centering will result in the shape being eccentric with the bore, spiraling, increased dig marks at the start, oversized holes, and reduced tool life. Centering the broach tool with the work can be achieved in or out of the machine. However, the most accurate way to indicate the tool is in the machine and on the tool station that will be used for broaching.

For machines like turret lathes that cannot place the tool accurately with the spindle centerline, an adjustable broaching head should be used to compensate for center. With an adjustable head, a gauge pin that is the same length as the broach is inserted into the head, and the very tip is indicated on to find center.

Adjusting Centering Off-Line

Set the indicator tip (5) on the gage pin (4) at the correct “L.” Rotate the holder on its shank



FIG 6

(2) in the preset fixture (1) to obtain a max. TIR of .0008". (Notice the oscillation of the gage pin as it rotates with the holder). Adjust the position using the four adjusting screws, and upon completion clamp the head tight with the clamping screws. Check again after clamping (see fig. 3).

Adjusting Center on the Machine

Adjustment for center on the machine offers the advantage to correct misalignment between the machine spindle and the turret bore. With the gage pin (4) set to the proper "L," set the broach head in the turret station (1) to be used for broaching. Set the indicator (5) onto the spindle chuck with a magnetic base. Place the indicator tip on to the end of the gage pin. Rotate the chuck so that the indicator sweeps the diameter of the pin and adjust accordingly using the adjusting screws (see fig. 4).

For Swiss-Type and Gang Machines

Another problem that has become more apparent in recent years is the smaller space requirements inside machines. As features and more tools are packed into the newest generation of sliding headstock and gang machines, the size of the tool holders also need to be reduced in size.

Newest to the line of PCM's broach holders is the 2160 series, designed for Swiss type machines. Co-developed by PCM and Genevieve, the 2160 has a maximum diameter of just over an inch and a head length of just less than 2-1/2" to the tip of the broach, easily fitting into machines with the tightest of tooling layouts. It comes with an extended

tool shank, allowing it to be cut shorter for machines with limited space. The proprietary bearing is able to withstand over 2000lbs of push force. The 2160 is customizable, it can be used for sub-spindle work, or any ID turret station without worrying about being off center. The unit can also be used by vertical machining centers for medium duty broaching less than 3/8" of an inch (see fig. 5).

HiCo8 Broach Tools

Not only is proper centering required for accurate broaching, it also helps to have a good tool to start with. The PCM broaches from Genevieve Swiss are tightly controlled and qualified. Many of the sizes aerospace manufacturers use must be held within .0004" on the hexagon diameter. Changeover is also extremely easy, since all broaches are qualified, which means that when a tool does wear out, it takes less than 30 seconds to change it out. The PCM broaches are made from HiCo8 high-strength European tool steel, which provides superior tool life. Many of the tools supplied by Genevieve Swiss also have a pressure vent that relieves oil and air as the tool enters a tight tolerance hole (see fig. 6).

Conclusion

Rotary broaching is a time-saving process that can eliminate expensive secondary operations and increase productivity and should be considered when symmetrical polygonal shaped features in parts are to be attained. Manufacturers of nearly any type of component can most certainly benefit from the process once they realize the time and cost savings. 

ABOUT THE AUTHOR:

Scott Laprade is with Genevieve Swiss Industries, Inc. To learn more call (413) 562-4800 or send e-mail to slaprade@genswiss.com.
Go online to [www.rotarybroaching.net] or [www.genswiss.com].