

THE PRINCIPLES OF WORKHOLDING: PART II

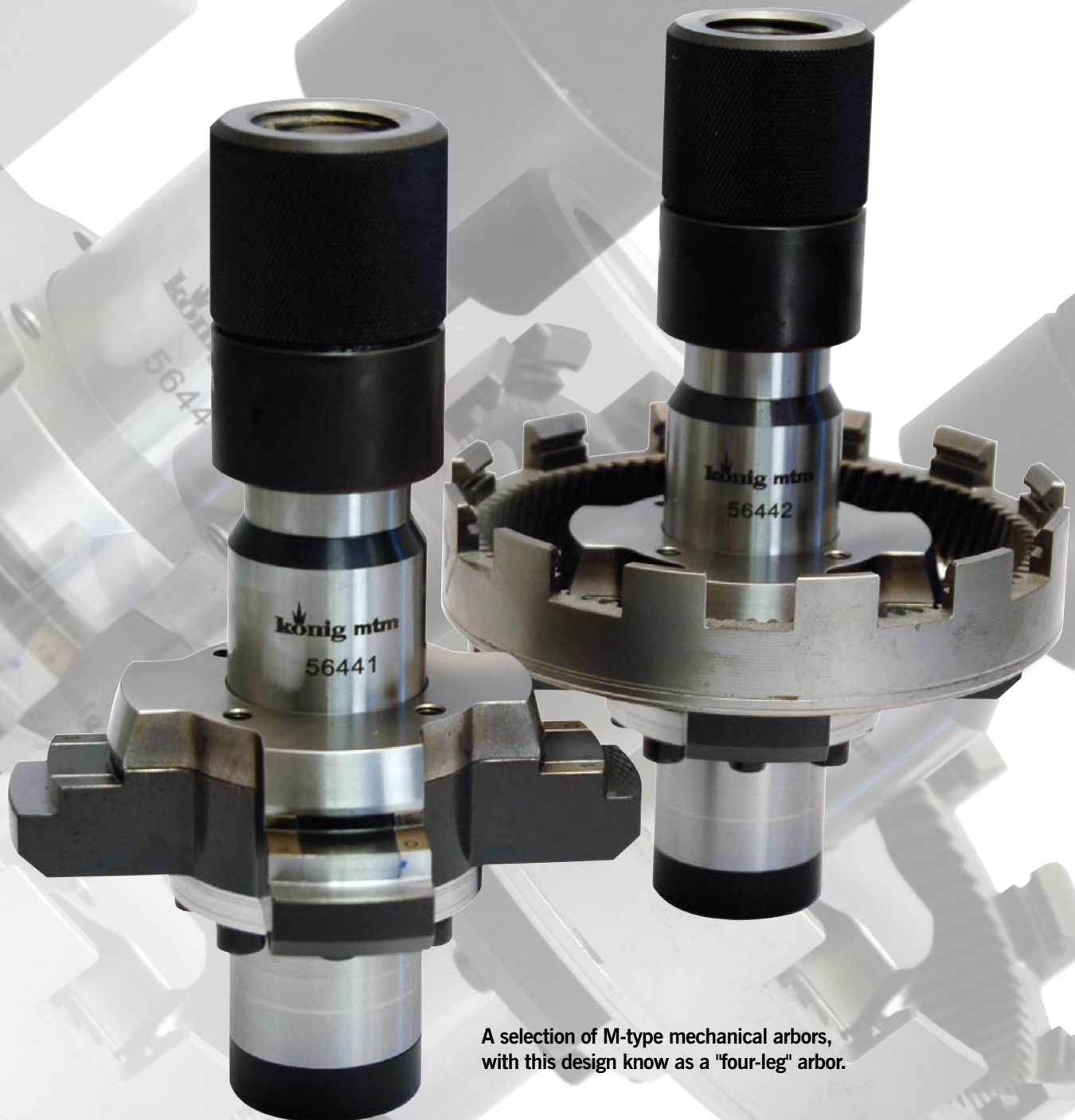

The second in a multi-part series on workholding, in this installment Toolink Engineering and König-mtm discuss the pros and cons of mechanical workholding devices.

By Juergen Kempf and Tim Peterson CMfgT



A selection of M-type mechanical arbors, with this design know as a "four-leg" arbor.

This is the second installment of a series of articles devoted to presenting and/or introducing the various designs—and principles behind the design—of workholding devices that have established a proven foothold within the gear manufacturing industry. The intent of this particular article is to discuss

mechanical workholding and identify its strengths, limitations, and areas of common usage. We have chosen to exclude inspection devices—both hydraulic and mechanical—and elected to include them in the third and final installment, which will include special applications and application-specific additions that can further customize your workholding.

As technology across all industries advances, the requirements of modern manufacturers continue to become more demanding and complex. Automated cells accelerate production, and the number of workpieces and/or tool variations rises sharply, while ideally maintaining a stable and controlled process.

While most are familiar with an automated production cell, be it gear grinding, honing, hobbing, etc., many initially overlook

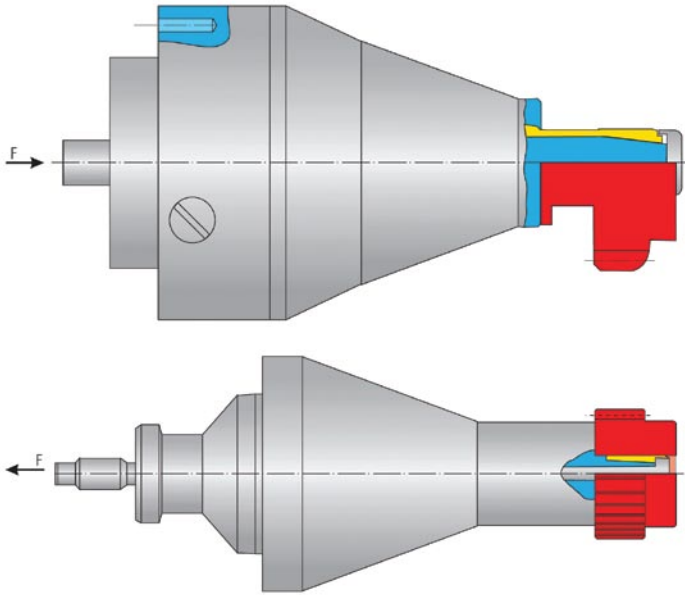

Fig 1: Type M1 single-taper mandrels showing clamping with push rod at top, and with pull rod at bottom.

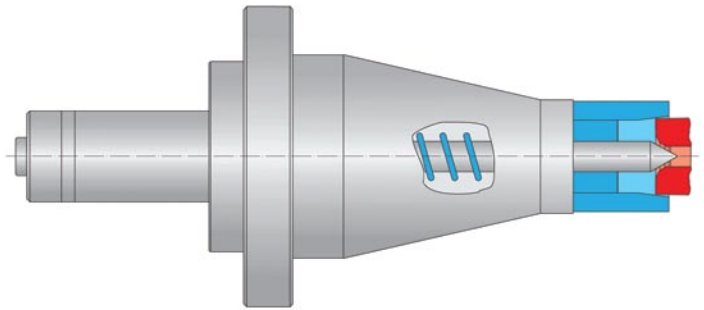

Fig 2: Type M4 friction taper chuck.

The Source for High Performance Castings



Ductile Iron, Meehanite®, Gray Iron ADI and High Silicon Ductile

- Expanded Capacity for Green Sand Molding - 350 to 1500 lbs, Flask Sizes
- Full Service Jobbing Foundry
- Prototypes to Medium Production
- Nobake Castings 500 to 40,000 lbs
- Green Sand Castings up to 500 lbs
- Pattern Shop On Site
- Complete Layout Facilities

Quality You Can Count on Today . . . and Tomorrow

WILLMAN INDUSTRIES

338 South Main St., Cedar Grove, WI 53013
Tel. (920) 668-8526 Fax. (920) 668-8998
E-mail: jhendrickson@willmanind.com Web Site: www.willmanind.com

MAXIMUM STORAGE in minimum space



Made by American Craftsmen in the USA

Stor-Loc®
Modular Drawer System

STOR-LOC MODULAR DRAWER SYSTEM
880 N. Washington Ave. Kankakee, IL 60901
Toll Free: 1800.786.7562 • Fax: 1800.315.8769
email: sales@storloc.com
www.storloc.com

the intricacies involved in the process, which is much like choreographing a complicated dance move. All the steps involved in such a performance must work together in perfect harmony, else the whole routine fails.

Loading clearances, as well as clamping force, play an important role in the field of automated production. While the abilities of today's robots and loading systems are very impressive, they still require more load/unload clearance than their human counterparts with their magnificent, opposing thumbs. This need for greater clearances cannot always be accomplished with hydraulic expansion arbors and chucks—thus we begin the introduction to König's line of mechanical workholding devices. We will start with single taper arbors and chucks, including the lesser-known friction taper chuck, followed by another newcomer, the König G-type, or multi-taper, arbors and chucks. To finish we will introduce the newest of the mechanical devices, the E-type, or elemental, fully segmented mechanical clamping arbor.

The most commonly recognized method of workpiece clamping is likely the single taper design arbor or chuck (see fig. 1). Such devices operate with a male taper on the base arbor and a female taper on the slotted collet, or the reverse for a chucking application. With the introduction of either a push or a pull force, the collet expands or contracts over the single tapered surface. This method is often employed for components with shorter clamping lengths and/or large clamping diameters, where higher clearances are necessary for automatic loading. Depending on the design of the device and/or the machine tool, clamping collets can be changed to accommodate various component diameters for greater flexibility. Single taper mechanical arbors and chucks are an excellent choice when the application demands high clamping force and an increased clamping range.

Clamping can be initiated either hydraulically or mechanically over a push or pull system depending on your machine configuration, while internal spring packages can assist with either clamping or unclamping as necessary. For chucking applications a spring or hydraulic center can also be integrated into the design to better align shaft-type workpieces and assist in auto loading/unloading.

When limited space is available for a clamping device, or where small shaft-type components are manufactured, König has a quick and simple solution; the friction taper chuck (see fig. 2). The chuck consists of a female (internal) tapered opening with a carbide insert

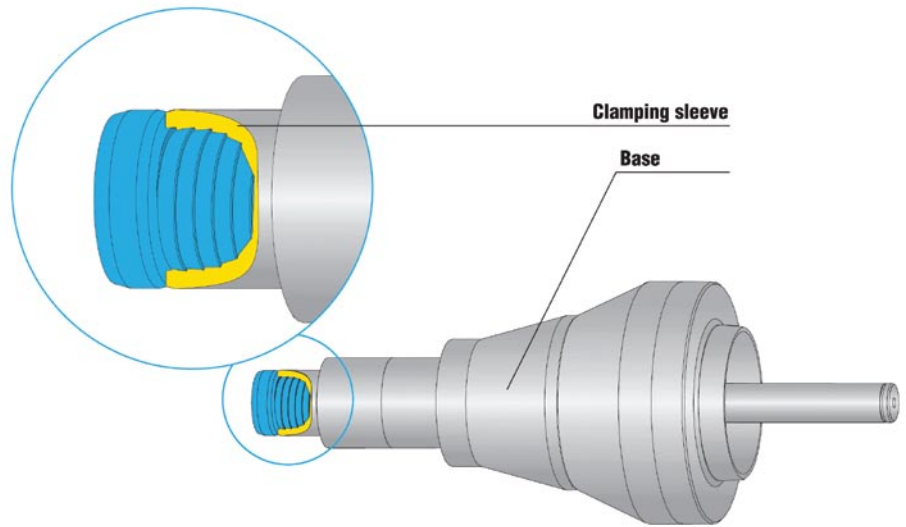
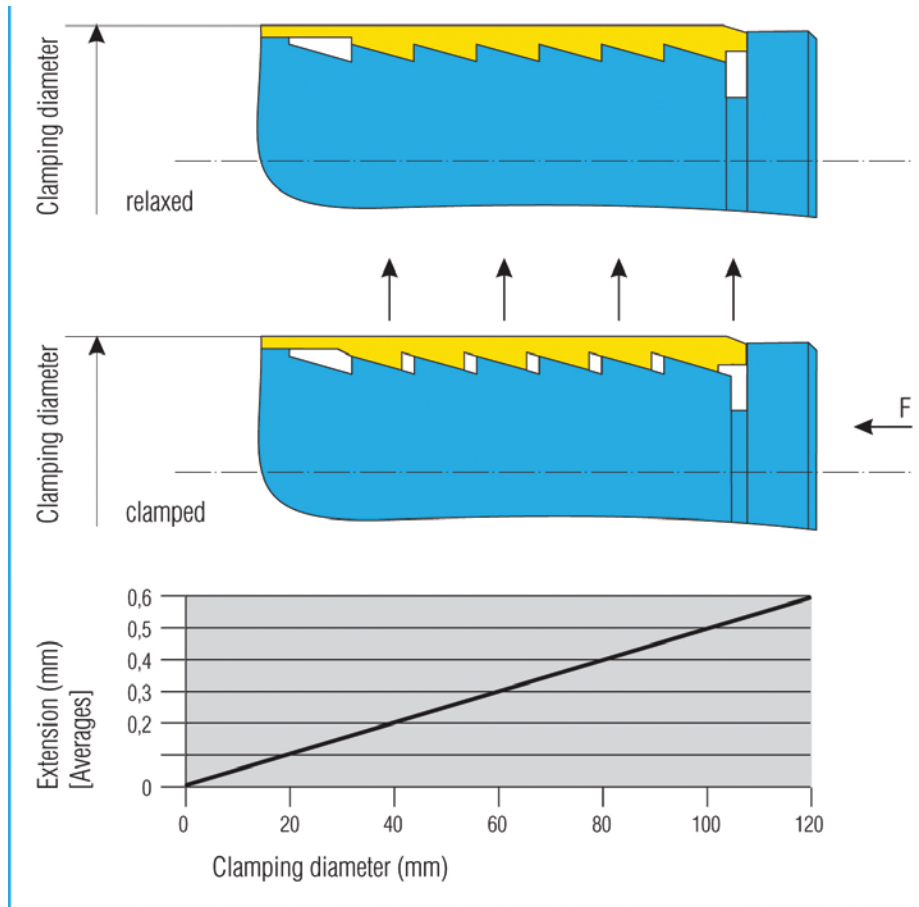

Fig. 3: The cylindrical extension of a multi-taper clamping tool at left, example of G-series multi-taper clamping tool at top.

to reduce wear. The workpiece is set into the taper via a live tailstock center, with sufficient force to achieve the desired torque transmission unto the component during processing. To assist with unloading, an ejector center can be included. Despite the simplicity of the chuck, high run-out accuracy is consistently attainable.

Multi-Taper Arbors and Chucks

For workpieces starting with a clamping diameter of 10mm, König-mtm offers clamping mandrels and chucks with clamping sleeves that are threaded with the base arbor/chuck body. Over this special thread profile the clamping sleeve

(collet) moves axially over the multiple tapers once the axial actuation force is introduced. This creates an extremely high contact area between the clamping collet and the basic mandrel. The result is a fully cylindrical uniform expansion of the collet over the entire clamping area. The parallel wall thickness of the collet

grants an even expansion, combined with excellent run-out accuracy at the clamping diameter.

Thanks to the cylindrical expansion these multi-taper, or G-type devices (see fig. 3) are ideal candidates for short clamping lengths and small clamping diameters, as well as medium and larger clamping diameters and lengths. In addition, provided the special collet design, it is not mandatory to grind the end faces of the workpieces. Compensating floating systems, or wobble plates, are used in this instance as necessary. The expansion rate over the multi-taper is also quite impressive, allowing increased loading clearances while maintaining a heightened lateral rigidity and high torque transmission unto the workpiece. Given the threaded design of the collets, a fast changeover to other clamping diameters is as easy as a few turns of the collet, enabling you to achieve maximum flexibility, quality, and economy. As with all König devices, the multi-taper arbors and chucks are available in multiple actuation methods depending on the configuration of your machine and application needs.

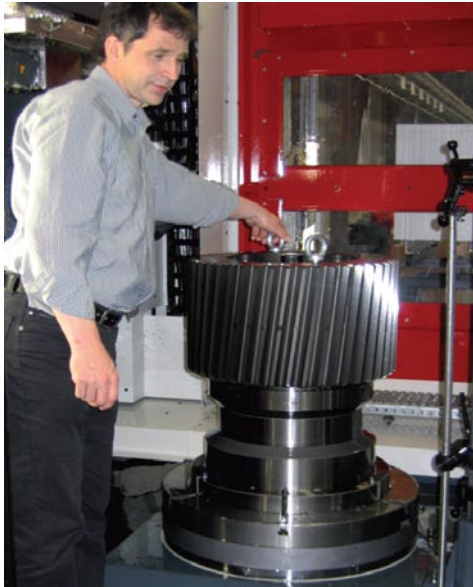

E-type Arbors

To meet and exceed requirements for higher work-piece tolerances and increased loading clearances, König-mtm has recently developed a new series of mechanical mandrels, the E-type, with fully segmented collet elements (see fig. 4).

Ideally suited for medium and large clamping diameters, these mechanically expanding clamping tools, depending on their size, offer expansion rates of 0.5 up to 1.3mm. This new clamping system consists of a basic single tapered mandrel, a collet (various diameters can be fitted to the same device) and, for example, a pull rod. The collet is comprised of several elements that are held together mechanically with an elastic, positive-locking spline. The mechanical connection between the collet segments offers improved permanent elasticity and precision over a purely vulcanized segment-to-segment bond connection. Additionally, given the individual segment design of the collets, they are able to provide increased hardness (64 HRC) and, therefore, wear resistance, while providing extremely high clamping force, high run-out accuracies, and incredible expansion, allowing for virtually unheard of work piece flexibility at such precision.

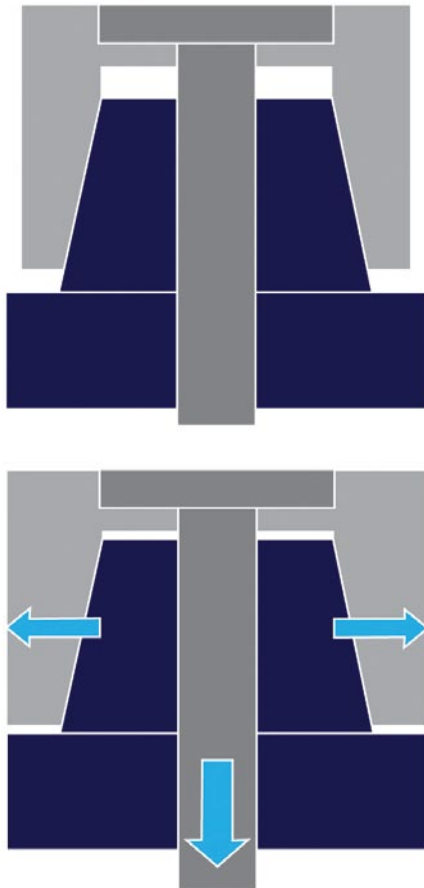

Fig. 4: Königdom® Type-E clamping tool with a diameter of 360mm at top. At bottom, the function principle of a fully segmented mechanical clamping mandrel.

Avoiding the Gritty

Part of the “nitty gritty” of mechanical workholding involves avoiding the “gritty.” While the design and function of single tapered workholding is rather straightforward, some extra care should be exercised to keep the devices clean. The same applies to all mechanical devices, as their function relies upon two or more opposing tapers moving across one another, so care must be taken to limit the introduction of contaminants such as dirt, swarf, and chips, etc., from interfering with their motion. Assuming the devices are kept clean before and after use, mechanical expansion arbors and/or chucks will provide many years and thousands of cycles of use. Although mechanical arbors and chucks are typically more expensive than their hydraulic counterparts, depending on their complexity, they do fill the gaps that hydraulic devices simply can't. 🦊

ABOUT THE AUTHORS:

Tim Peterson, CMfgT, is the engineering and sales manager for Toolink Engineering, the exclusive North American distributor of the König line of workholding. Juergen Kempf is a mechanical engineer and technical sales manager for König-mtm in Wertheim, Germany, and the primary technical contact for North-American customers. Peterson can be reached at (303) 776-6212 or tpeterson@toolink-eng.com. Visit online at www.toolink-eng.com or www.koenig-mtm.de.